

SPECIFY DESIGN SP070212-3
& DRAWER WIDTH TO GET A QUOTE

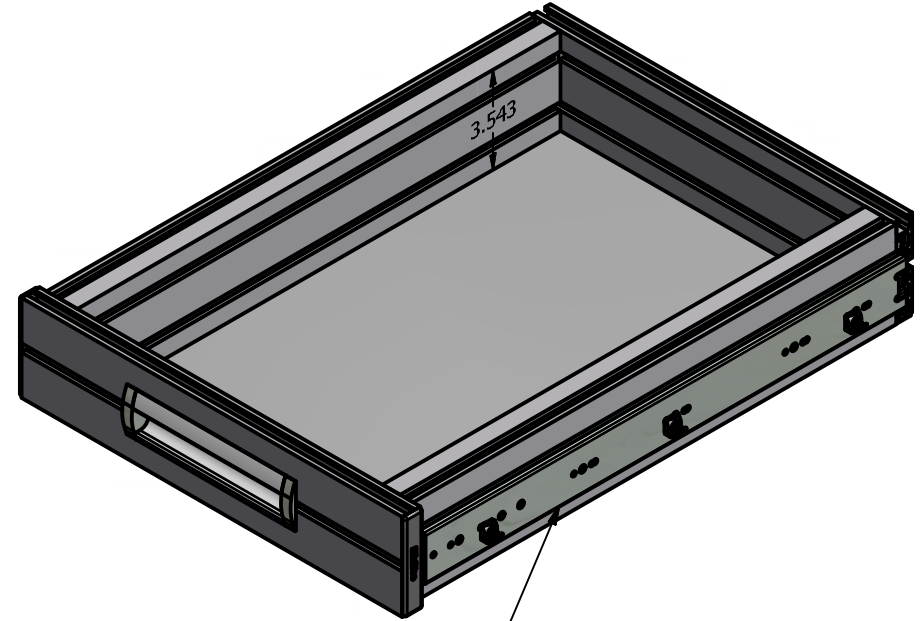

20" TRAVEL BALL BEARING
DRAWER SLIDES 95 LB/PAIR
(OTHER LENGTHS AVAILABLE)

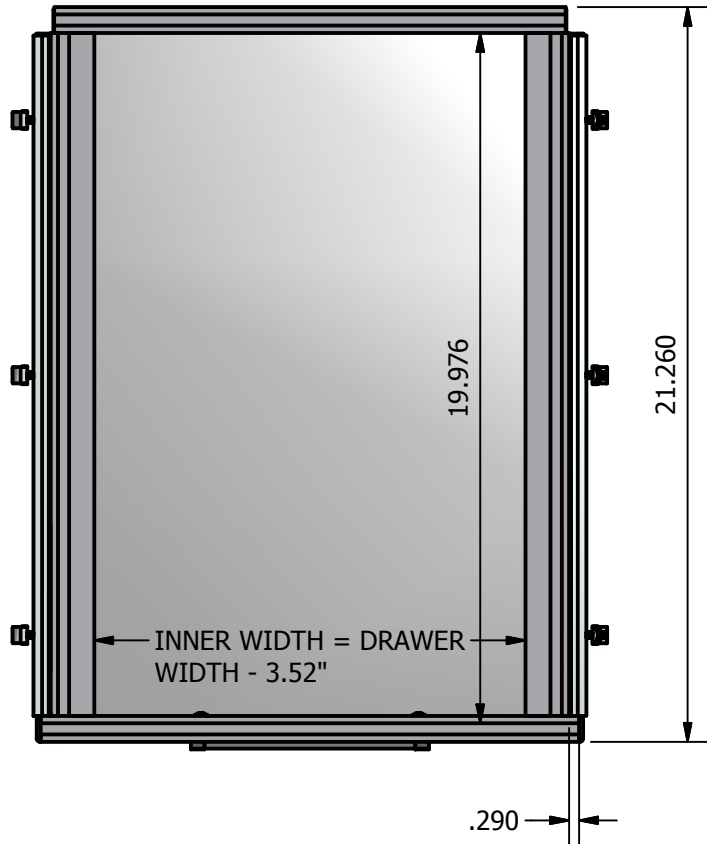
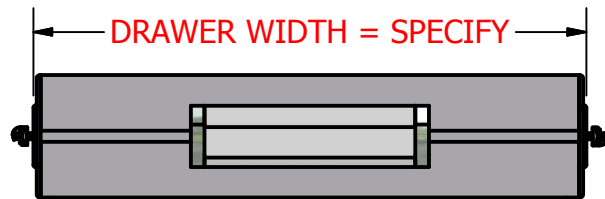

PROJECT SP070212-3 SHOP PRINTS			WWW.MINITECFRAMING.COM	
DRAWN BY ANDY MOLES			VICTOR, NY	
DATE 6/29/2012			PH # 585 924-4690 FX # 585 924-4821 amoles@minitecframing.com	
DRAWN FOR MINITEC'S CUSTOMER	TITLE 90X19 DRAWER	DWG NO SP070212-3	REV	
TOLERANCES UNLESS OTHERWISE NOTED X +/- .125" .XX +/- .015" .XXX +/- .010"		MATERIAL		SHEET 1 OF 7
		FINISH		

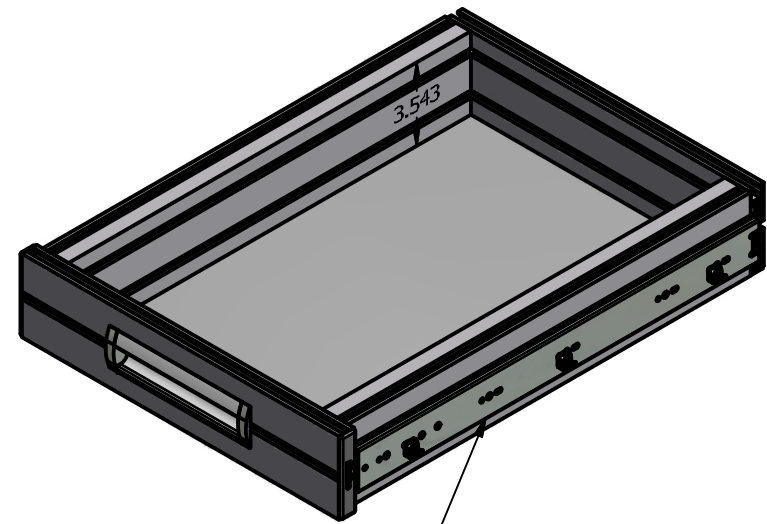
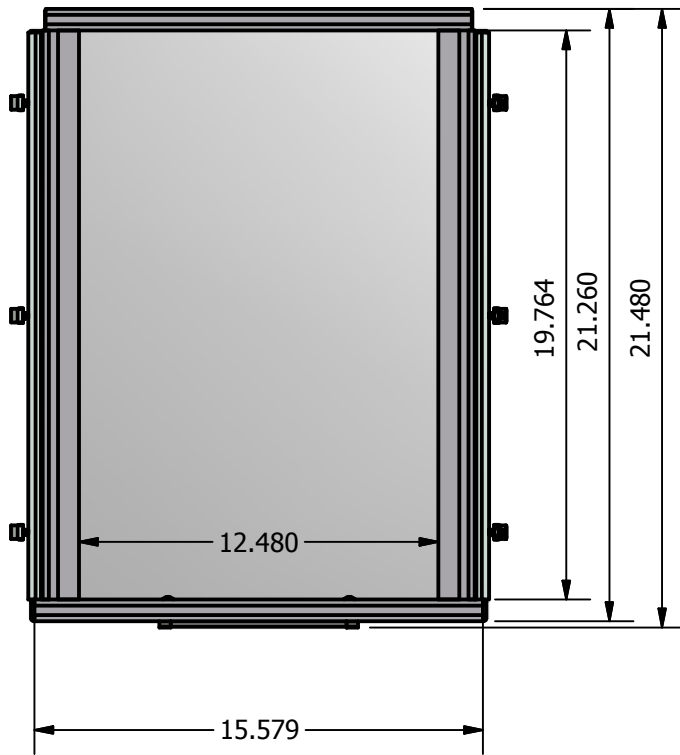

20 INCH TRAVEL DRAWER SLIDE
95 LB LOAD RATING/PAIR

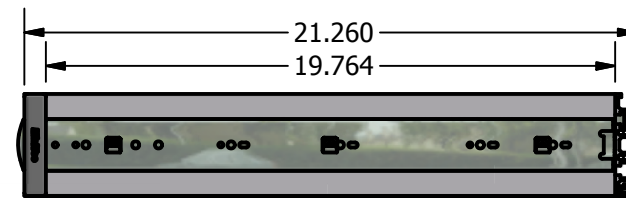
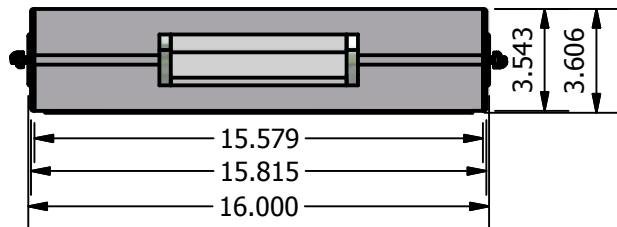

PROJECT SP070212-3 SHOP PRINTS			WWW.MINITECFRAMING.COM	
DRAWN BY ANDY MOLES			VICTOR, NY	
DATE 6/29/2012			PH # 585 924-4690 FX # 585 924-4821 amoles@minitecframing.com	
DRAWN FOR MINITEC'S CUSTOMER	TITLE 90X19 DRAWER	DWG NO SP070212-3	REV	
TOLERANCES UNLESS OTHERWISE NOTED .X +/- .1/32" .XX +/- .015" .XXX +/- .010"		MATERIAL		SHEET 2 OF 7
		FINISH		

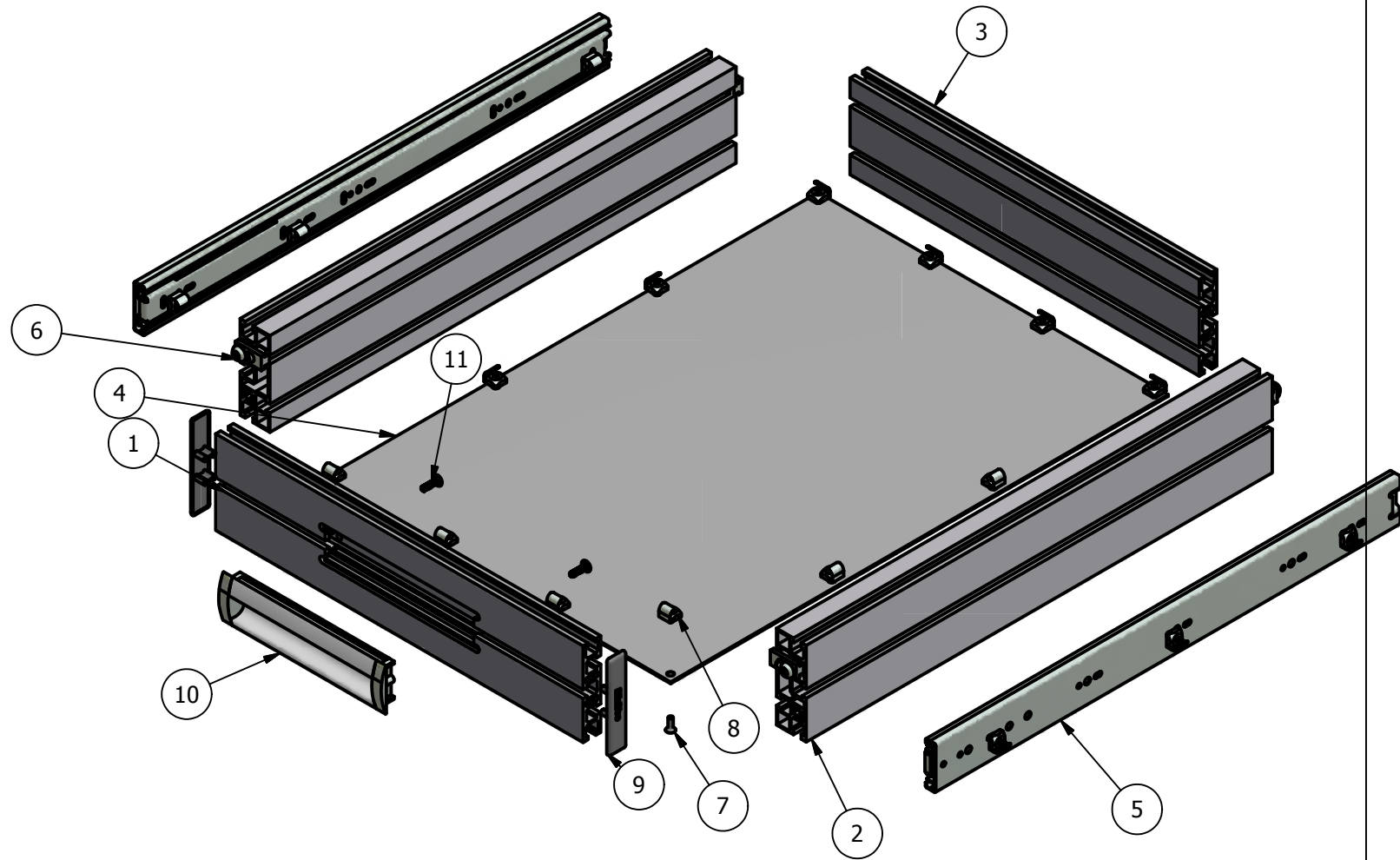

PARTS LIST QTY 1

ITEM	PART #	MATERIAL	DESCRIPTION	QTY
1	SP070212-3-1	20.0995 PROFILE 90X19	MACHINE TO SP070212-3-1	1
2	SP070212-3-2	20.1066 PROFILE 90X32 UL	PL SAME HOLE BOTH ENDS 90, REM SLOT TO SP070212-3-2	2
3	SP070212-3-3	20.0995 PROFILE 90X19		1
4	SP070212-3-5	21.9525/1 AL PANEL 1/16" ANODIZED	MACHINE TO SP070212-3-5	1
5	32.9805 HALF		1/2 OF SET OF DRAWER SLIDE 20	2
6	21.0818		POWER-LOCK SF	4
7	21.1948		CSUNK M4X12	12
8	21.1310/2		M4 SQUARE NUT W/ POS FXG	12
9	22.1014/1		END CAP 90X19 GRAY	2
10	21.9308		FLUSH PULL 160 AL	1
11	21.9945		M4X16 BUTTON HEAD FLANGE	2

PROJECT SP070212-3 SHOP PRINTS			WWW.MINITECFRAMING.COM	
DRAWN BY ANDY MOLES			VICTOR, NY PH # 585 924-4690 FX # 585 924-4821 amoles@minitecframing.com	
DATE 6/29/2012		TITLE 90X19 DRAWER		DWG NO SP070212-3
DRAWN FOR MINITEC'S CUSTOMER		MATERIAL		REV
TOLERANCES UNLESS OTHERWISE NOTED X +/- .12" .XX +/- .015" .XXX +/- .010"		FINISH		SHEET 3 OF 7