

SPECIFY DESIGN # SP070212-4
& DRAWER WIDTH TO GET A QUOTE

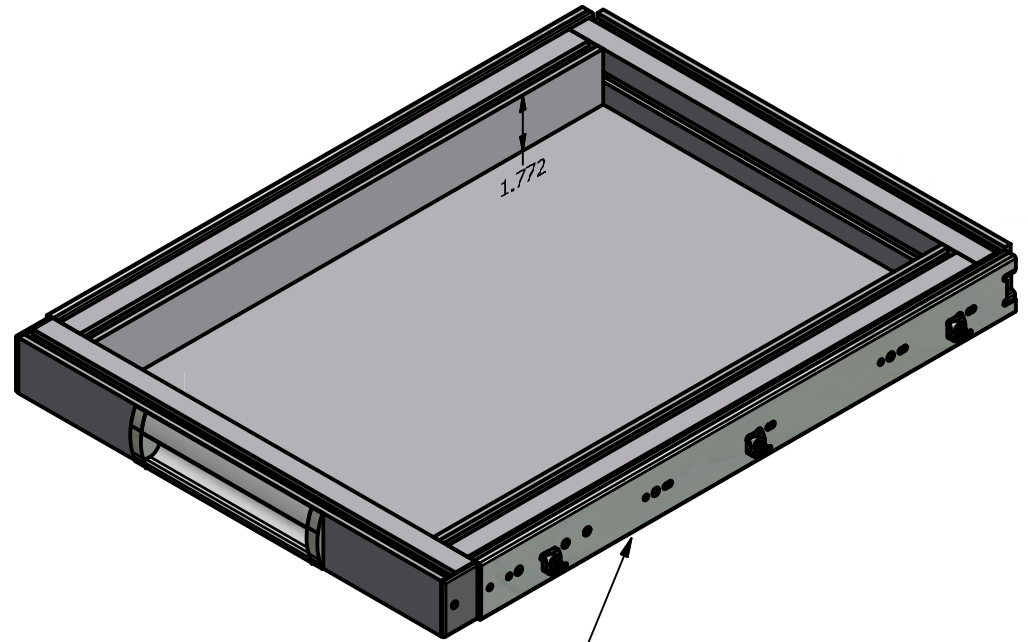

20" TRAVEL BALL BEARING
DRAWER SLIDE 95 LB/PAIR
(OTHER LENGTHS AVAILABLE)

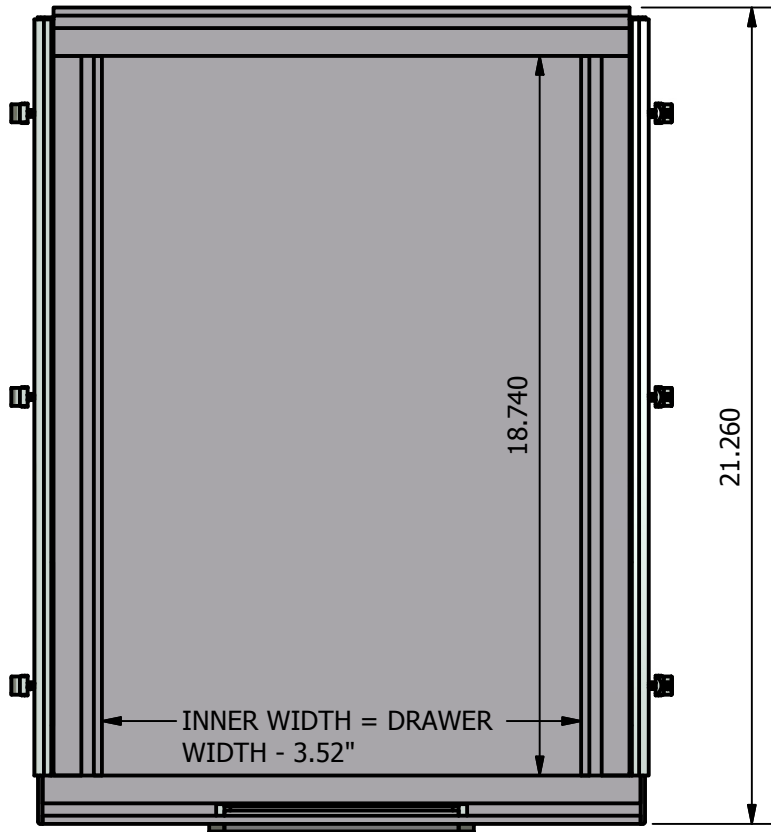
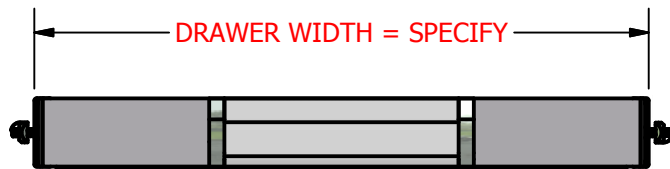

PROJECT SP070212-4 45mm DRAWER			WWW.MINITECFRAMING.COM	
DRAWN BY ANDY MOLES			VICTOR, NY	
DATE 7/6/2012			PH # 585 924-4690 FX # 585 924-4821 amoles@minitecframing.com	
DRAWN FOR MINITEC'S CUSTOMER	TITLE DRAWER 45mm DEEP	DWG NO SP070212-4	REV	
TOLERANCES UNLESS OTHERWISE NOTED .X +/- .1/32" .XX +/- .015" .XXX +/- .010"		MATERIAL		SHEET 1 OF 5
		FINISH		

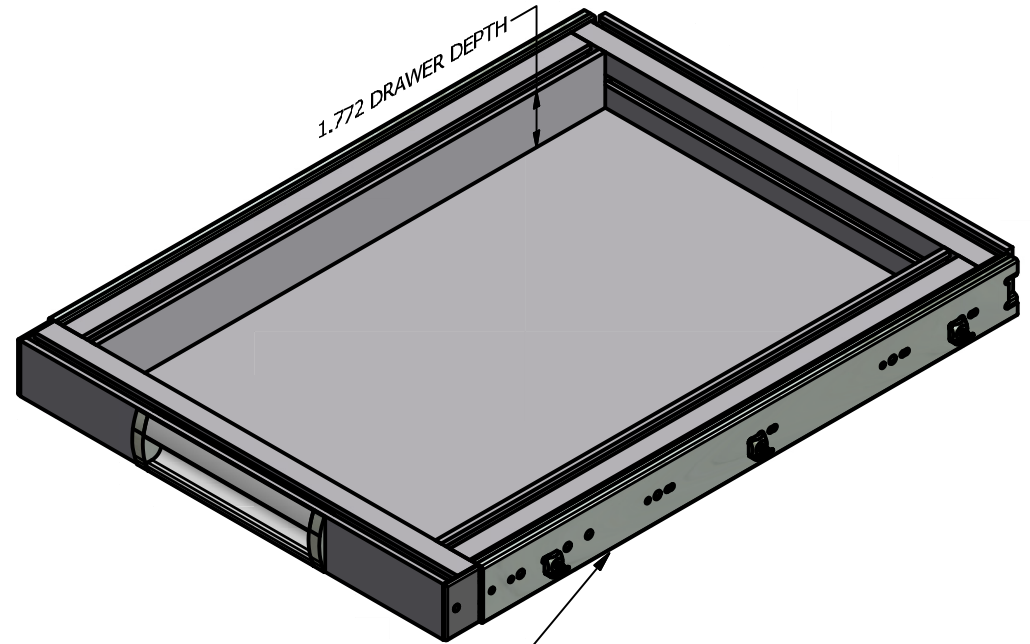
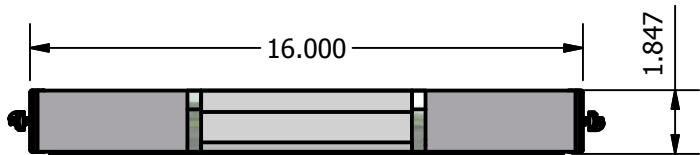
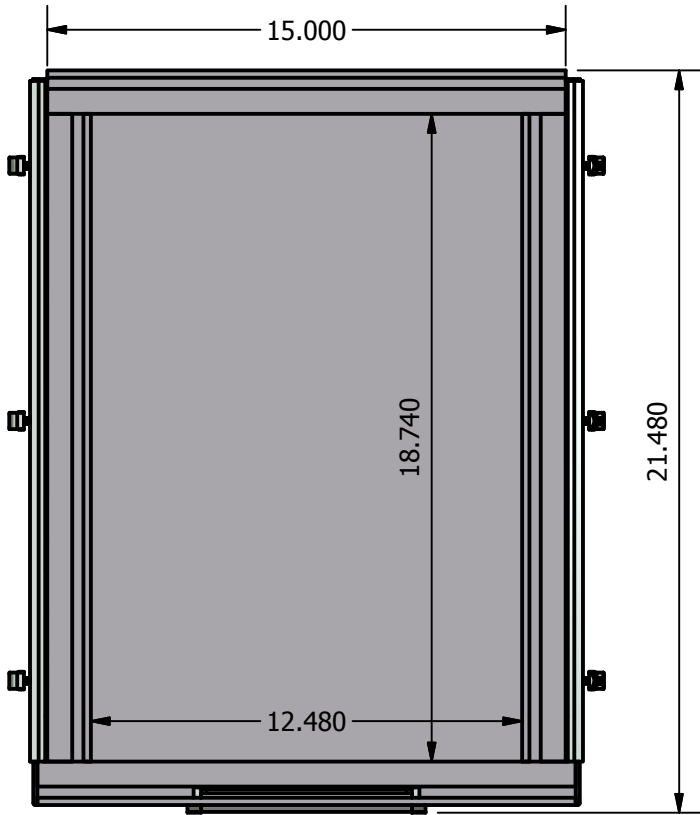

20" TRAVEL DRAWER SLIDE
95 LB/PAIR LOAD RATING



PROJECT SP070212-4 45mm DRAWER			WWW.MINITECFRAMING.COM	
DRAWN BY ANDY MOLES			VICTOR, NY	
DATE 7/6/2012			PH # 585 924-4690 FX # 585 924-4821 amoles@minitecframing.com	
DRAWN FOR MINITEC'S CUSTOMER		TITLE DRAWER 45mm DEEP	DWG NO SP070212-4	REV
TOLERANCES UNLESS OTHERWISE NOTED .X +/- .1/32" .XX +/- .015" .XXX +/- .010"		MATERIAL		SHEET 2 OF 5
		FINISH		

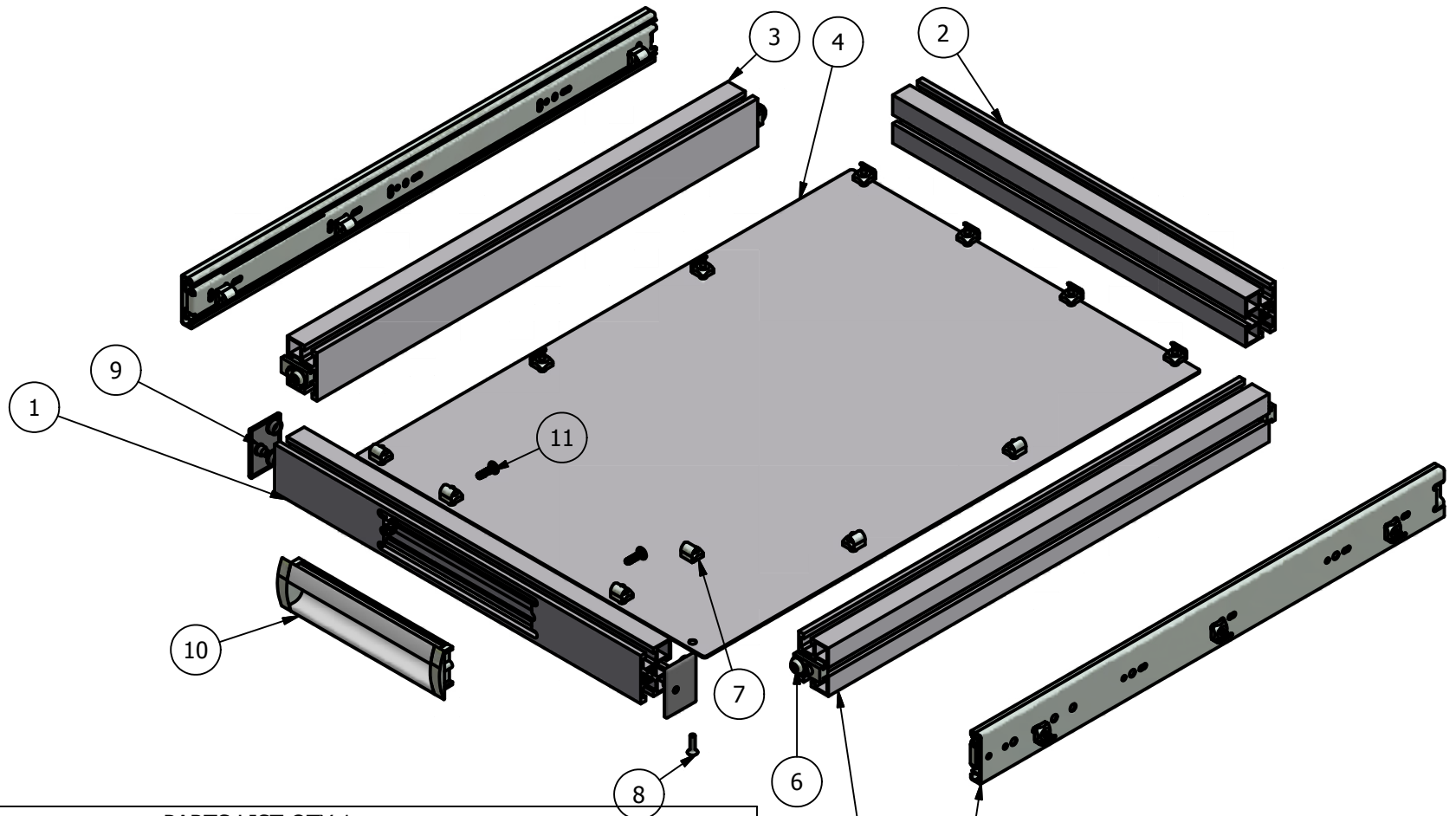

PARTS LIST QTY 1

ITEM	PART #	MATERIAL	DESCRIPTION	QTY
1	SP070212-4-1	20.1065 PROFILE 45X32 UL	MILL TO SP070212-4-1	1
2	SP070212-4-3	20.1065 PROFILE 45X32 UL	BACK PROFILE 45X32 UL	1
3	SP070212-4	20.1065 PROFILE 45X32 UL	INSTALL POWER-LOCKS ON BOTH ENDS 45	2
4	SP070212-4-5	21.9521/1 1/16" ANODIZED AL	MACHINE TO SP070212-4-5	1
5	32.9805 HALF		1/2 OF SET OF DRAWER SLIDE 20	2
6	21.0818		POWER-LOCK SF	4
7	21.1310/2		M4 SQUARE NUT W/ POS FXG	12
8	21.1501		M4x16 C'SUNK	12
9	22.1003/1		END CAP 45x32 Z GRAY	2
10	21.9308		FLUSH PULL 160 AL	1
11	21.9945		M4X16 BUTTON HEAD FLANGE	2

PROJECT SP070212-4 45mm DRAWER		MiniTec THE ART OF SIMPLICITY	WWW.MINITECFRAMING.COM	
DRAWN BY ANDY MOLES			VICTOR, NY PH # 585 924-4690 FX # 585 924-4821 amoles@minitecframing.com	
DATE 7/6/2012		DWG NO		REV
DRAWN FOR MINITEC'S CUSTOMER		TITLE DRAWER 45mm DEEP		SP070212-4
TOLERANCES UNLESS OTHERWISE NOTED .X +/- .12" .XX +/- .015" .XXX +/- .010"		MATERIAL		SHEET 3 OF 5
		FINISH		