

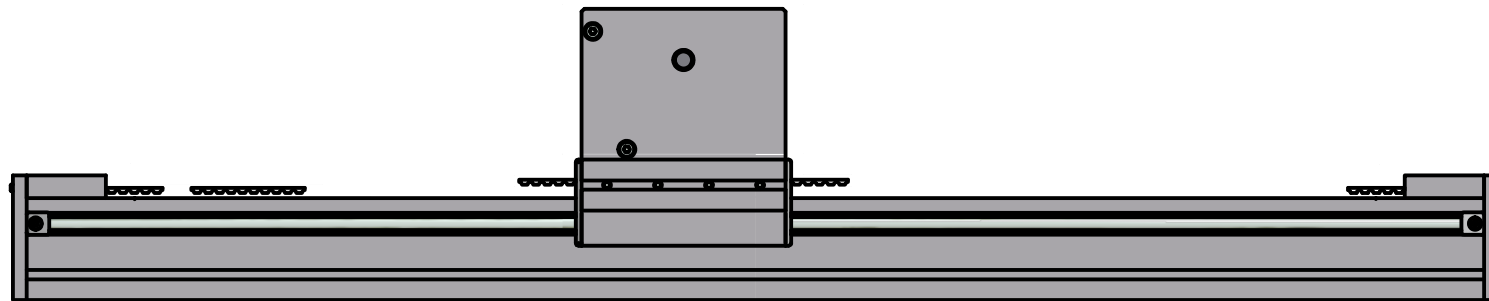

TRAVEL = RAIL LENGTH -(2*TENSIONER LGTH)-SLIDE LGTH-(2* SAFETY GAP)=

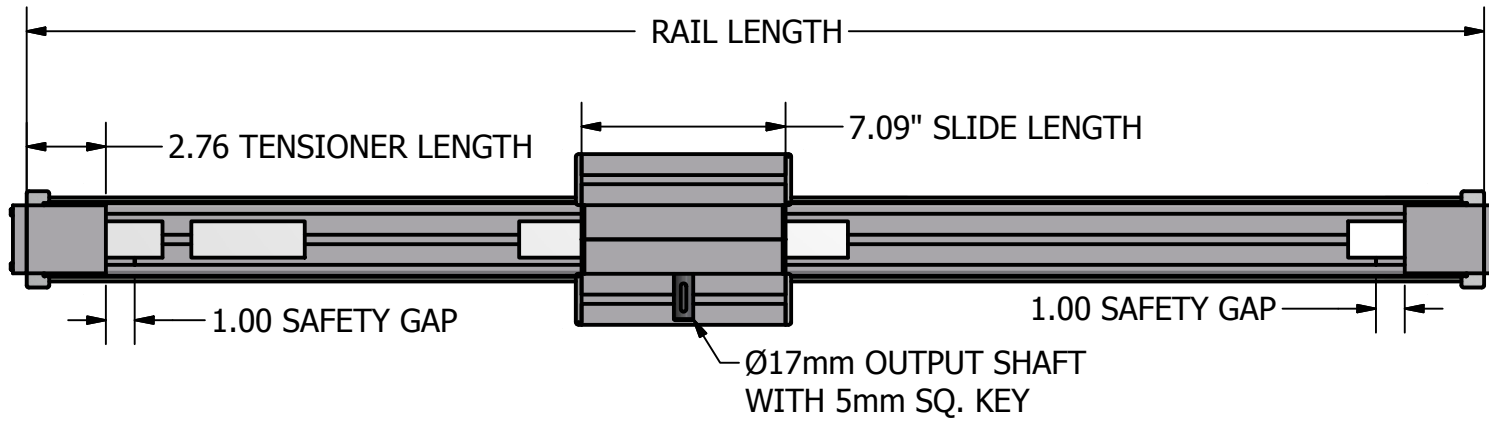

45X90 F PROFILE

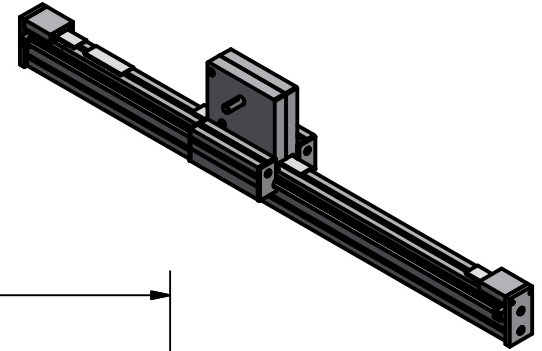
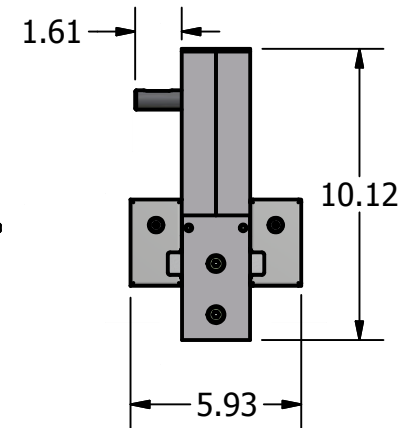

PROJECT SP021413-1		 WWW.MINITECFRAMING.COM VICTOR, NY PH # 585 924-4690 DIRECT 585 398-1240 EXT 104 FX # 585 924-4821 amoles@minitecframing.com	
DRAWN BY ANDY MOLES			
DATE 3/4/2013			
DRAWN FOR MINITEC'S CUSTOMER	TITLE ADD TITLE	DWG NO SP02142013-1	REV
TOLERANCES UNLESS OTHERWISE NOTED .X +/- .12" .XX +/- .015" .XXX +/- .010"		MATERIAL	
FINISH		SHEET 1 OF 2	

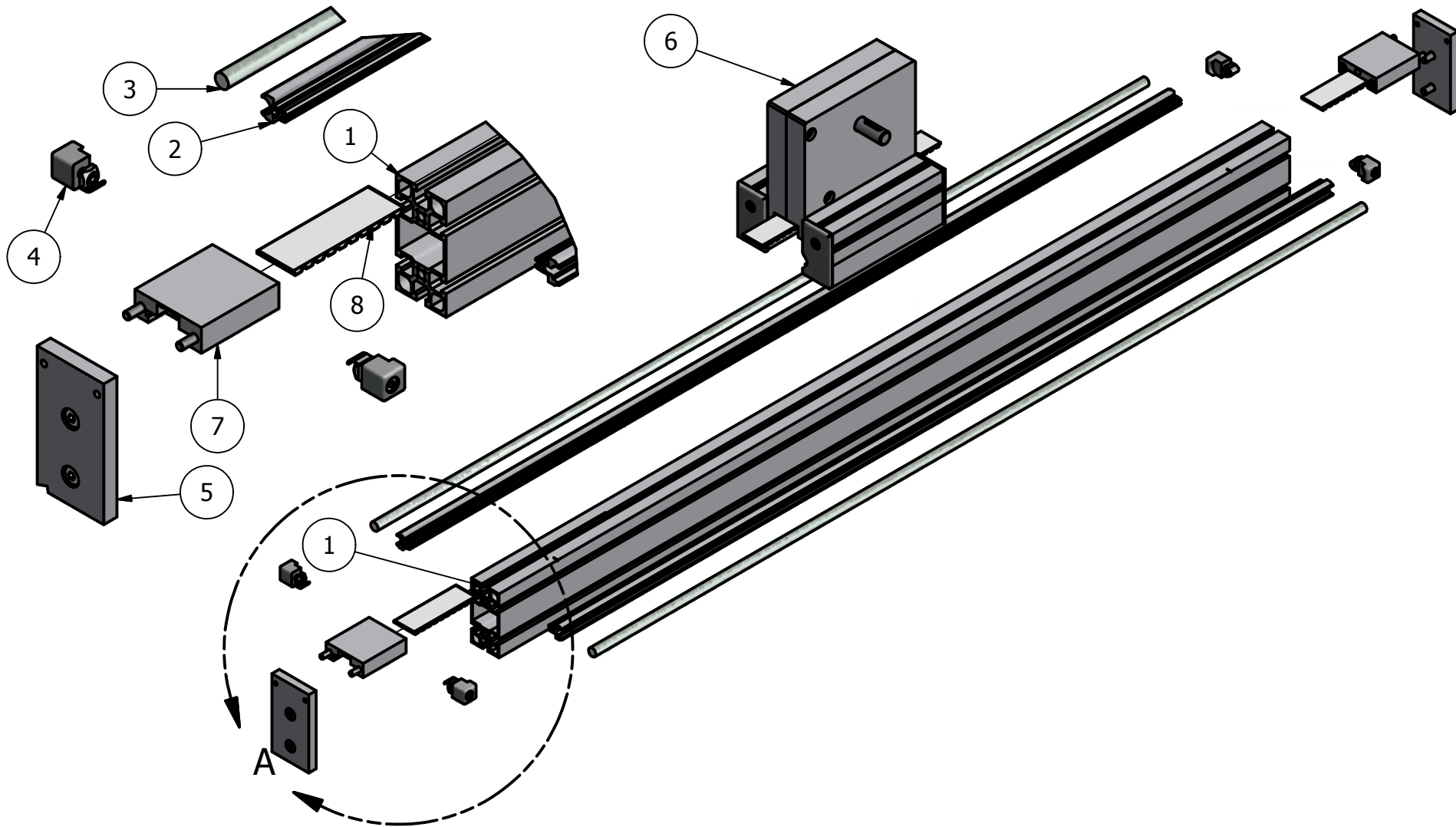

PARTS LIST

ITEM	PART NUMBER	DESCRIPTION	QTY
1	20.1032	PROFILE 45X90 F	1
2	28.0002	SHAFT SUPPORTING PROFILE	2
3	17.1741	SHAFT 12	2
4	28.0052	SHAFT RETENTION DEVICE	4
5	28.0056	FASTENING KIT FOR TIMING BELT TENSIONER 45X90H	2
6	28.0248	BELT DRIVE 45	1
7	28.0090	TIMING BELT TENSIONER	2
8	28.0093	TIMING BELT 32 AT 10	1

PROJECT SP021413-1			<small>WWW.MINITECFRAMING.COM VICTOR, NY PH # 585 924-4690 DIRECT 585 398-1240 EXT 104 FX # 585 924-4821 amoles@minitecframing.com</small>	
DRAWN BY ANDY MOLES			DWG NO	REV
DATE 3/4/2013		SP02142013-1		
DRAWN FOR MINITEC'S CUSTOMER	TITLE ADD TITLE	MATERIAL		
<small>TOLERANCES UNLESS OTHERWISE NOTED X +/- .12" .XX +/- .015" .XXX +/- .010"</small>		FINISH	SHEET 2 OF 2	